



OLIVETEL SA

OLirack[®]

19" FLOOR-STANDING ENCLOSURE CABINETS

OLIVETEL SA

CONTENTS

Contents

General information, standards and CE compliance _____	1
Introduction _____	1
_____	1
Standards and ce compliance _____	1
Range and Configurations _____	2
Diversity of configurations _____	2
Basic RANGE _____	2
Standard setup _____	2
Reliable with Productivity, Quality and Safety _____	3
Some functional advantages _____	3
Safety and quality assurance _____	3
Make your own configuration _____	3
Illustrative photos _____	4
_____	5
Scalability and Accessories _____	6

OLIRACK – FLOOR-STANDING ENCLOSURE CABINETS

General information, standards and CE compliance

INTRODUCTION

With over two decades of evolution, due to the ongoing experience with Designers and IT Service Integrators, the **OLIRACK Floor-Standing Rack Enclosure Cabinets** was designed to IT installations and telecommunications equipment in several contexts. Characterized by their high quality, durability, functionality and scalability, provides a wide range of configurations and options to your project.



STANDARDS AND CE COMPLIANCE

- 19" according EIA 310 D / DIN 41 494 / IEC 60 297
- IP20 according DIN 400 50 / IEC 60 529
- European directives 2014/35/CE (Low Voltage Electrical Equipment)
- European directives 2014/53/CE (telecommunications terminal equipment)

OLIRACK – FLOOR-STANDING ENCLOSURE CABINETS

Range and Configurations

DIVERSITY OF CONFIGURATIONS

Besides the Standard Setup presented, a wide range and different settings with **Perforated Single or Double Doors, Glass Double Doors, Flat Steel Single or Double Doors and Perforated Panels** are available.

BASIC RANGE

U's	Height (mm)	Width (mm)			Depth (mm)		
15	771	600	700	800	600	800	1000
24	1171	600	700	800	600	800	1000
30	1438	600	700	800	600	800	1000
36	1705	600	700	800	600	800	1000
42	1971	600	700	800	600	800	1000
47	2193	600	700	800	600	800	1000

*** For different dimensions contact us ***

STANDARD SETUP

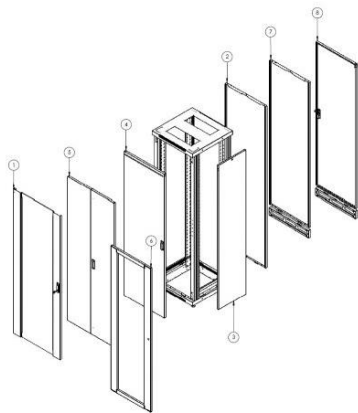

- **(1x)** Chassis structure - Max Load 800Kg / w/terminal to earth ground connection
- **(1x)** Top Module with pre-cuts for ventilation system and cable routing
- **(1x)** Tempered glass front door w/lock handle and key w/earthing terminal (1x) Rear Panel w/lock and key w/earthing terminal
- **(2x)** Side Panels w/lock and key w/earthing terminal
- **(4x)** 19" Rack Mounting Profiles w/ Adjustable depth system
- **(1x)** Open Bottom Module for cable routing
- **(4x)** Adjustable height levellers

- COLORS : RAL 7035 or Anthracite (similar RAL 9005)

OLIRACK – FLOOR-STANDING ENCLOSURE CABINETS

Reliable with Productivity, Quality and Safety

Time is a crucial factor in installation projects and the quality of the components that are handled as well. Our product range were conceived and designed to make installation productive and safe. For this purpose, in the **OLIRACK FLOOR-STANDING RACK ENCLOSURE CABINETS** range, are included a set of details that are the result of 20 years of expertise, providing critical projects implemented by multinational leading companies such as **IBM, VODAFONE, SONY, COLT, SIEMENS, ERISSON** and many others who trust in our brand.

SOME FUNCTIONAL ADVANTAGES

- Easily removable door with hinge spring system.
- Reversible door, can be installed opening for both sides.
- Removable rear and side panels.
- Rack profiles with depth adjustment.
- Pre cuts in coverage for ventilation system or cable routing.
- All units prepared to be installed in row

SAFETY AND QUALITY ASSURANCE

- All components (doors and panels) connected through terminals for grounding connection.
- Tempered Glass (Glass doors configuration) as European standards.
- Surface treatment with 80 µm of epoxy-polyester textured w/polymerization, designed for industrial applications that confers high mechanical strength and excellent protection of steel sheet.
- Totally free from hazardous materials, Manufacture according to European Directive.



MAKE YOUR OWN CONFIGURATION

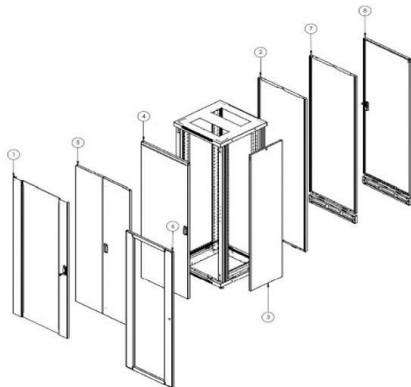

If the previous STANDARD SETUP does not respond to your needs, you can define your own configuration. The modular characteristics of our OLIRACK cabinets, allow a wide range of different compositions, which can be incorporated a different types of components such as **Single or Double Perforated Doors, Single or Double Flat Steel Doors, Single or Double Glass Doors and performed panels.**

If our standard dimensions are an issue for you, don't worry, it can be done. This is a huge differentiation that has OLIRACK compared to another brands.

OLIRACK – FLOOR-STANDING ENCLOSURE CABINETS

Illustrative photos

OLIRACK[®]



OLIRACK – FLOOR-STANDING ENCLOSURE CABINETS

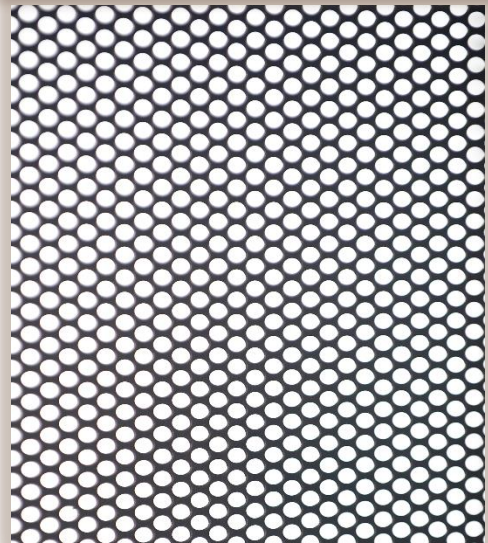

OLIRACK – FLOOR-STANDING ENCLOSURE CABINETS

Scalability and Accessories

The ability to increase value in your installation, was previously thought in the design and manufacturing process, so scalability is ensured. A wide range of components and accessories are available:

- Brush strip for cables;
- Ventilation Systems;
- Filters
- Pedestals
- Fixed or Slide Trays
- Blanking panels
- Lighting Kits
- PDU and Power strips (simple or w / switch)
- Crossing Cables Grids to doors and rear panel's application
- Specific and Custom accessories
- Etc.

For a better understanding of existing solutions, we advise you to consult the table of existing accessories OLIRACK on our website or contact our Technical / Commercial area for personalized and assertive advice.

Company Head Office Information

OLIVETEL SA

Rua da Cruz nº66 Naves Industriais A-B-C-D – Algueirão – 2725-663 Mem Martins
Portugal

Tel (+351) 21 922 98 40

Fax (+351) 21 922 98 50

Email: comercial@olivetel.pt

www.olivetel.pt

